

Identifikace třídy záloh pro třmeny Knorr-Bremse



Kontrolní kroky

1) Tlačítka

2x Tlačítko



1x Tlačítko

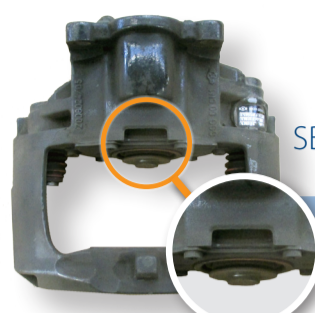

SB5, SN5

DC5

2) Příruba

Axiální



Radiální

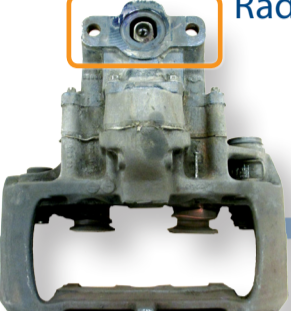

SB7R

DC4

3) Těleso

Mono



Dělený

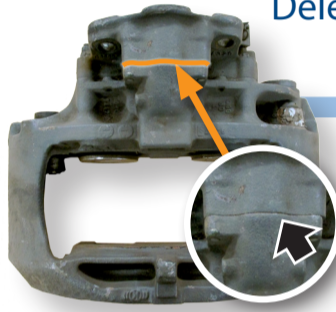

Zkontrolujte šrouby na odlitku

SB6

SB7

DC6

DC8

3a) Monoblok
Základová deska
Směr montáže



2 vnější šrouby
namontované ze
strany válce

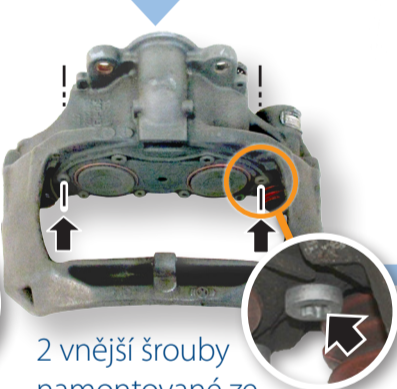

2 vnější šrouby
namontované ze
strany kolečka

Zkontrolujte odlitek

SM7

SN7

ST7

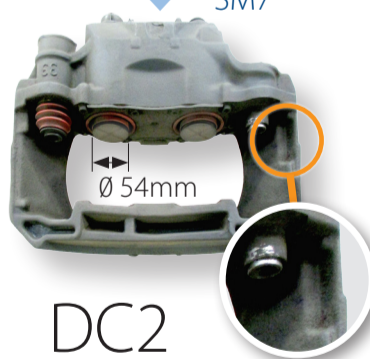

DC2

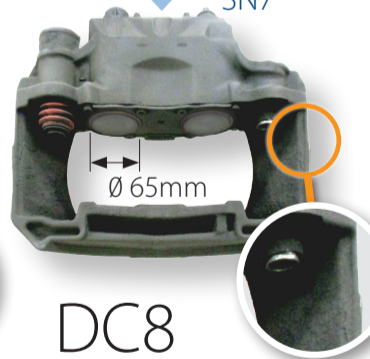

DC8



DC9 'S' tvar
pevnostní
části

Zkontrolujte
rozlišující prvky

Hlava šroubu
zapuštěná do odlitku

SL7

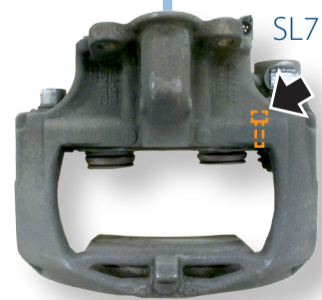

DC2

Tvar odlitku

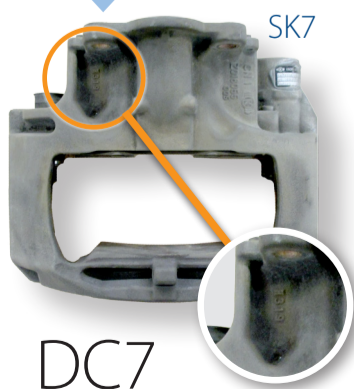

DC7

2 drážky

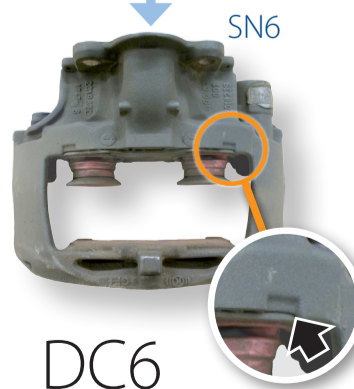

DC6